



# AN002: Wiring Two Countryman Microphones to One Transmitter

*Abstract: This application note outlines a method for connecting two Countryman B3s to a single transmitter. This technique can be useful for certain miking applications (i.e. recording both feet of a tap dancer) where two separate mics are required but a second transmitter is not practical. When possible, using two transmitters will provide more flexibility as the microphone gains may be independently adjusted. The two microphones should be separated as much as possible to avoid phasing.*

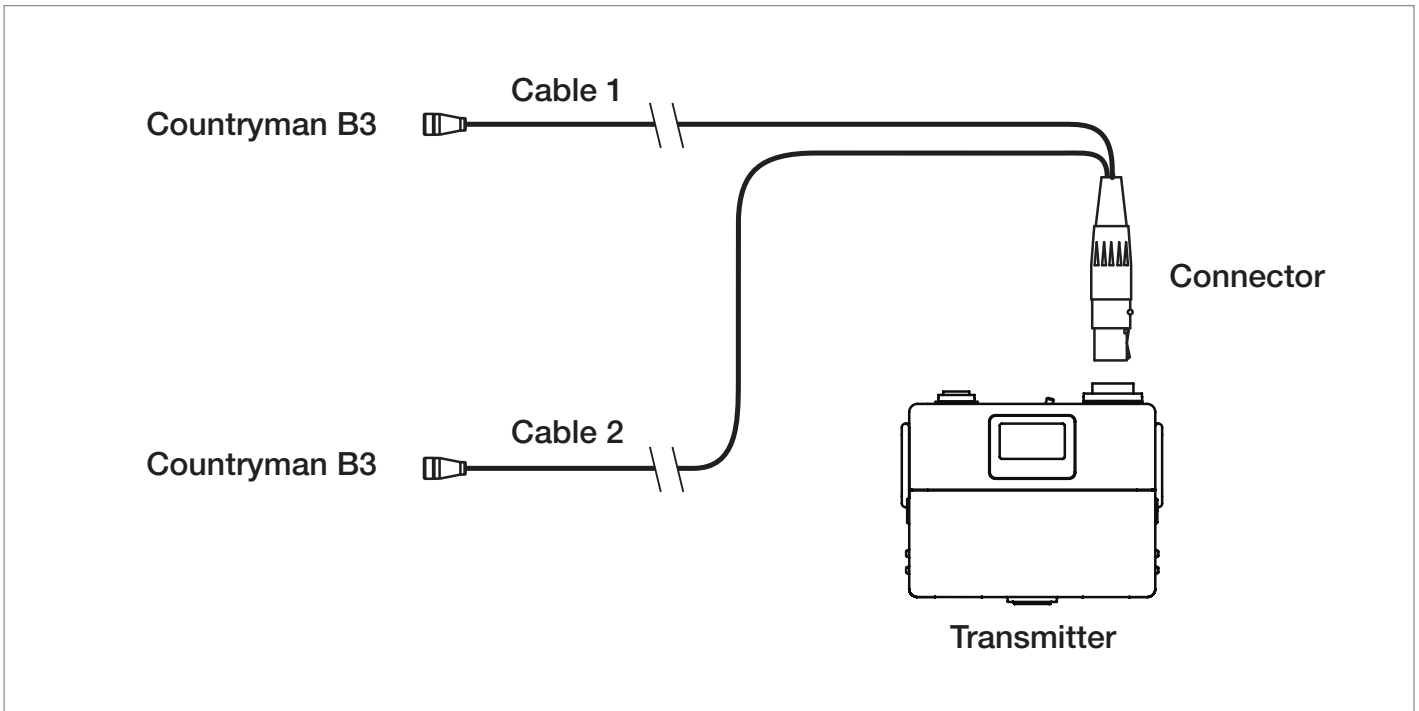

Figure 1: Physical diagram of a two Countryman B3 microphones connected to a single transmitter.

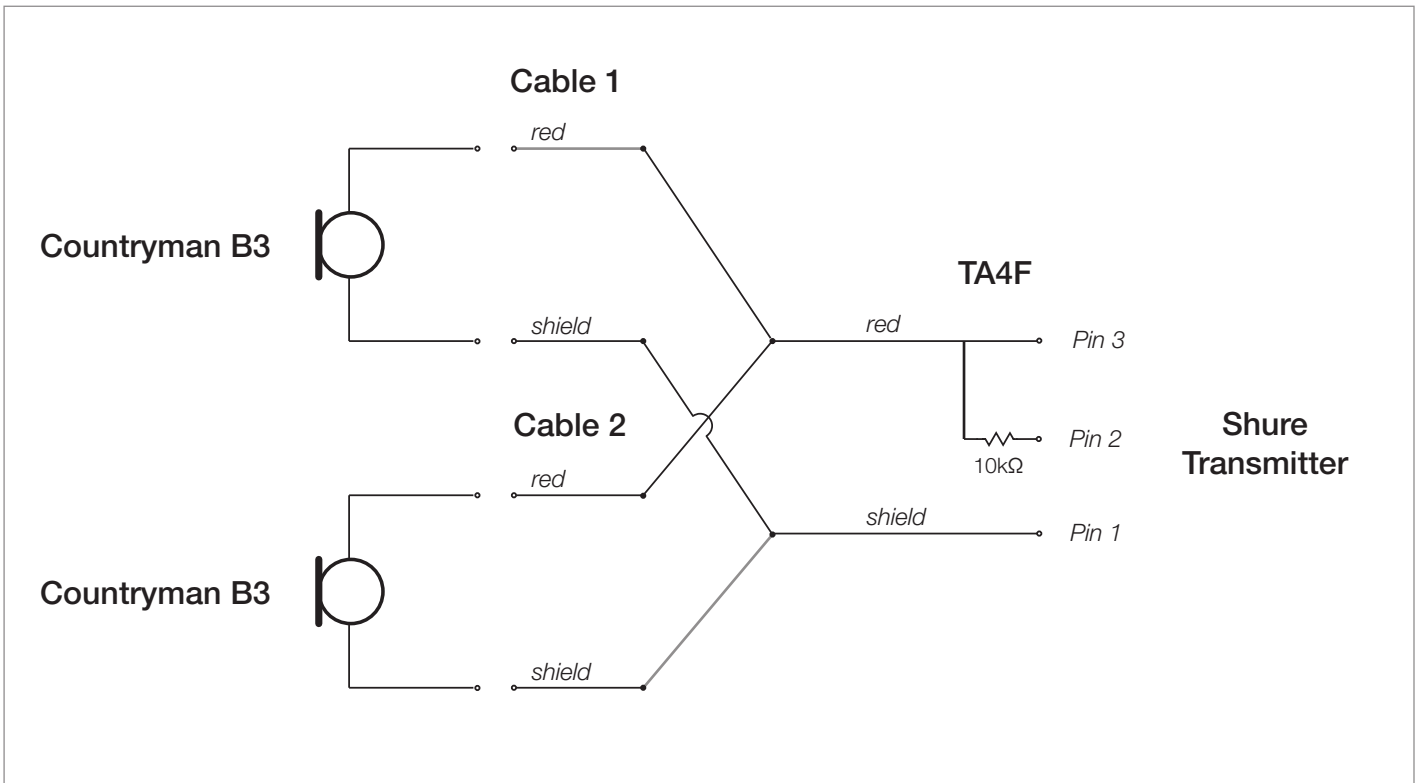

Figure 2: Example electrical diagram of a two B3 microphones connected to a single Shure transmitter.